

ECLIPSE TS100

CFI60



Eclipse TS100. Adding new dimensions to inverted microscopes



CFI 60 objectives

In designing the new microscope, Nikon started with its acclaimed CFI60 optical system—a fusion of CF optics with infinity optics—into this new, small-sized inverted microscope. These optics provide flat, sharp, and brilliantly clear images, while achieving longer working distances and higher numerical apertures. Furthermore, epi-fluorescence and HMC observations are now possible using accessories available as options. To improve observation under phase contrast microscopy, Nikon developed a series of Apodized Phase Contrast objectives, allowing minute details

within a specimen to be observed with excellent contrast and wider tonal ranges. But Nikon didn't stop here. They redesigned the body, so that it is robust, rigid, and vibration-resistant, and placed all controls so that they fall naturally under your hand. To accommodate image documentation, Nikon offers a trinocular model as well. The TS100-F comes with a photo port and accepts various photomicrographic systems, including a CCTV camera, or a digital still camera.



Binocular type Model TS100

Trinocular type Model TS100-F

Operation is simpler, quicker, more precise,
because there is less strain on the user

Coarse/fine focus knob

The coaxial coarse/fine focus knob, located in front of and close to the operator, makes operation at high magnifications more efficient and convenient than ever before.



Efficient, user-friendly stage

The stage features a low-profile design that is 195mm high, making it the ideal size for a lab bench or safety hood. Even cell cultures on the bottom of a tall flask or stacking chamber vessel can be viewed, because there is 190mm of space above the stage when the condenser is removed.

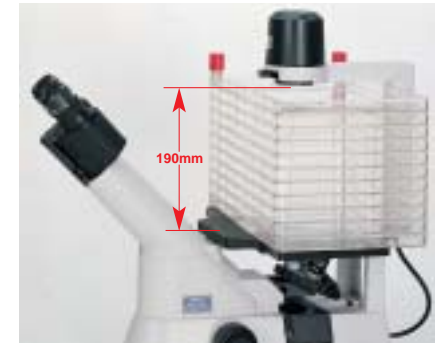

Ample space above the stage

Transparent stage ring

Two types of acrylic stage rings come with the main body. Because these stage rings are transparent, confirming which objective is being used is easy. The ring with the semicircular hole facilitates observation of the specimen in a chamber since it prevents the objective lens from striking the ring during magnification changes. A glass stage that minimizes the possibility of thermal deformation is also available as an option.



Acrylic stage ring set

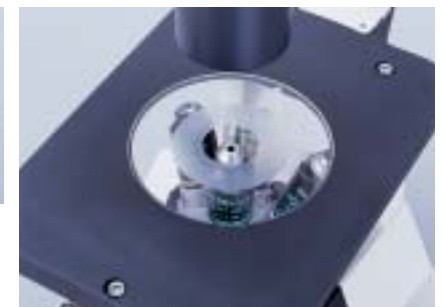

Objective in use is easily identified through the transparent stage ring.

Easy-to-rotate nosepiece

The quintuple (5-position) backward-facing nosepiece offers plenty of clearance to allow the operator to rotate it from either side. Because there is ample space around the nosepiece, handling the nosepiece is easy, even for an operator with large or gloved hands.



Plenty of clearance around the nosepiece

Eyepiece tube

The Siedentopf-type eyepiece tube is inclined 45° and the eyepoint height is 400mm for easy, comfortable viewing in the sitting or standing position.

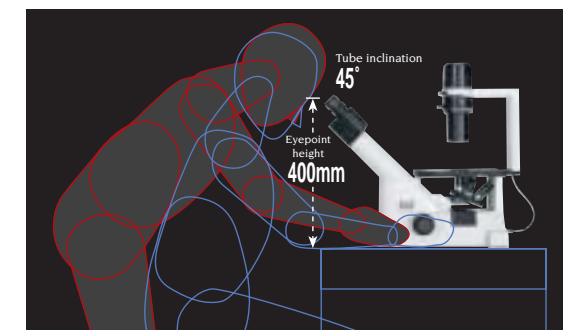

Comfortable operation

Eyepieces

Featuring a 22mm field of view, the widest in this class of microscope, the TS100/TS100-F ensures clear images up to the periphery of the field of view even when using higher magnification objectives.

Observation methods that provide the most information from your specimens

Phase contrast microscopy has never been easier, thanks to Nikon's New Apodized Phase Contrast objectives

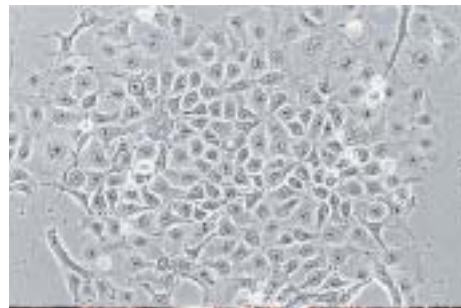

Monkey kidney



Rat brain glial cell

The phase contrast method doesn't require specimen staining, making it the ideal method for observing living cells and microorganisms. To improve images under this method, Nikon developed an innovative series of Apodized Phase Contrast objectives. These objectives produce images with excellent contrast and a much wider tonal range, shedding light on minute details within a specimen.

In addition, there is no need to change the annulus even when the 40X objective is selected. One condenser phase annulus works from 10X to 40X. The ELWD condenser achieves a long 75mm working distance and a high 0.30 numerical aperture, while delivering greater brightness.



ELWD condenser



TS100 configured with a phase contrast set

The Basic Principle of the Apodized Phase Contrast System

Nikon has succeeded in reducing halos in the image—considered difficult under phase-contrast microscopy—by improving the phase ring within the objective using a process called Apodization.

In an innovative design, Nikon analyzed different diffraction angles and the amount of phase differences created, then added extra light-absorbing bands to the Phase Ring DL. This improves vision under phase contrast microscopy, making it possible to observe cell division activities taking place within a specimen more clearly—hitherto often obscured by unwanted halos—or view finer details within a thick specimen.

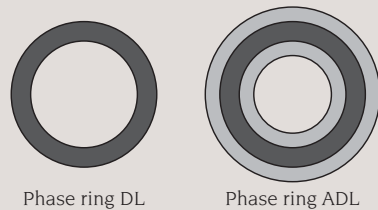

Phase ring DL

Phase ring ADL



ELWD condenser and phase sliders



- ① CFI Achromat ADL10X (N.A. 0.25, W.D. 6.2mm) Ph1
- ② CFI Achromat LWD ADL20XF (N.A. 0.4, W.D. 3.1mm) Ph1
- ③ CFI Achromat LWD ADL40XF (N.A. 0.55, W.D. 2.1mm) Ph1
- ④ CFI Achromat LWD ADL40XC (N.A. 0.55, W.D. 2.7-1.7 mm) Ph2
- ⑤ CFI Plan Fluor ELWD ADL 20XC (N.A. 0.45 W.D. 8.1-7.0mm) Ph1
- ⑥ CFI Plan Fluor ELWD ADL 40XC (N.A. 0.6 W.D. 3.7-2.7mm) Ph2

Epi-fluorescence method

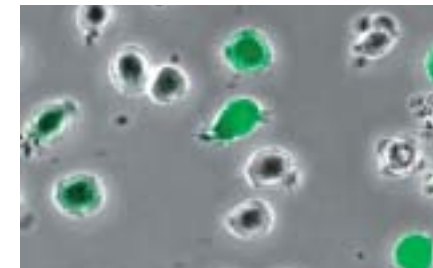

T lymphocyte cell (GFP)



Breast cancer screening (DAPI)

This method is ideal for identifying fluorescent tagged substances within a cell, green fluorescent protein (GFP), and a myriad of other clinical and research applications.

Epi-fluorescence observation utilizing UV-range light is also possible.



Epi-fl attachment



- ① CFI Plan Fluor DL4X (N.A. 0.13, W.D. 16.4mm) PhL
- ② CFI Plan Fluor DL10X (N.A. 0.3, W.D. 15.2mm) Ph1
- ③ CFI Plan Fluor ELWD DM20XC (N.A. 0.45, W.D. 8.1-7.0 mm) Ph1
- ④ CFI Plan Fluor ELWD DM40XC (N.A. 0.6, W.D. 3.7-2.7 mm) Ph2
- ⑤ CFI Plan Fluor 10X (N.A. 0.3, W.D. 16.0mm)
- ⑥ CFI Plan Fluor ELWD 20XC (N.A. 0.45, W.D. 8.1-7.0 mm)
- ⑦ CFI Plan Fluor ELWD 40XC (N.A. 0.6, W.D. 3.7-2.7 mm)
- ⑧ CFI Plan Fluor ELWD ADL 20XC (N.A. 0.45 W.D. 8.1-7.0mm) Ph1
- ⑨ CFI Plan Fluor ELWD ADL 40XC (N.A. 0.6 W.D. 3.7-2.7mm) Ph2



TS100 configured with epi-fl attachment

Hoffman Modulation Contrast® method



HeLa cells in tissue culture vessel

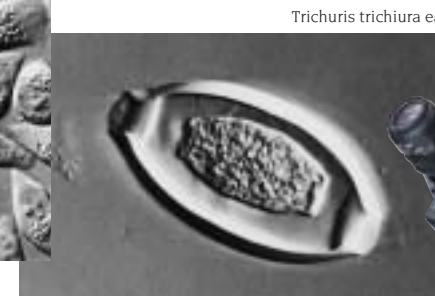

Trichuris trichiura egg

This method is now possible even with a microscope of this class. HMC creates vivid, 3-dimensional-like images of living, transparent specimens, allowing observation in plastic petri dishes—something that DIC does not do well.



HMC condenser



- ① CFI HMC 10X (N.A. 0.25, W.D. 6.2mm)
- ② CFI HMC LWD 20XF (N.A. 0.4, W.D. 3.9mm)
- ③ CFI HMC LWD 40XC (N.A. 0.55, W.D. 2.7-1.7 mm)



TS100 configured with an HMC set

Note: Hoffman Modulation Contrast and HMC are registered trademarks of Modulation Optics Inc.

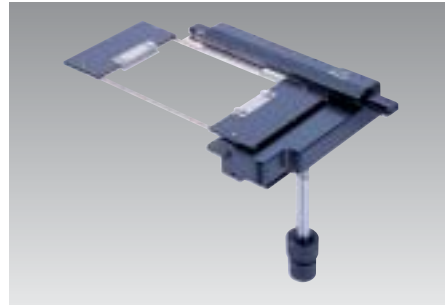

Mechanical stage

By attaching appropriate holders, various specimen slides and micro testplates can be mounted on this stage.

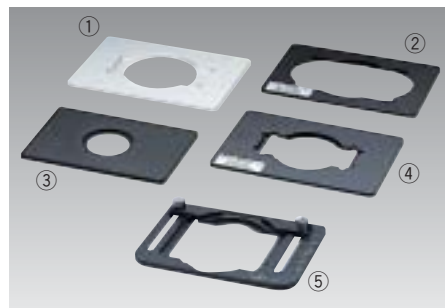

Specimen plate holders

These specimen holders are available for use with the mechanical stage:

- ① Hemacytometer holder
- ② Terasaki holder (accepts ø65mm petri dish)
- ③ ø35mm petri dish holder (included on the main body of the TS100/100-F)
- ④ Slide glass holder (accepts ø54mm petri dish)
- ⑤ Universal holder



Auxiliary stages

For large specimens, you can widen the space on your plain stage by attaching a pair of auxiliary stages.



Micromanipulators

The Eclipse TS100/100-F can be configured with Nikon/Narishige micromanipulators and microinjectors for a variety of applications, including injections, aspiration, and incisions of cell tissues during cytoengineering, developmental and genetic engineering, electrophysiology, pharmacology, reproductive medicine, and neurochemistry.

Photomicrographic systems including a CCTV or digital still camera



TS100-F configured with Digital Camera DS-5M-L1



With a photomicrographic equipment H-III

With a CCTV camera

The TS100-F comes with a photo port that accepts photomicrographic systems such as the DS-5M-L1, a stand-alone type digital camera with which you can take photos without PCs. Also a CCTV or photomicrographic equipment can be attached.

CCTV adapters

These CCTV adapters are available as options:

- C-mount TV adapter 0.6X—recommended for 2/3" CCD camera*
- C-mount TV adapter 0.7X—recommended for 2/3" CCD camera
- C-mount TV adapter 0.45X—recommended for 1/2" CCD camera*
- C-mount TV adapter 0.38X—recommended for 2/3" CCD camera*
- C-mount TV adapter VM4X**
- C-mount TV adapter VM2.5X**
- C-mount TV adapter A
- C-mount TV adapter used with Relay Lens 1X*
- ENG-mount TV adapter 0.6X—recommended for 2/3" CCD camera*
- ENG-mount TV adapter 0.45X—recommended for 1/2" CCD camera*
- ENG-mount TV adapter used with Relay Lens 1X*

* V-T photo adapter is necessary
** C-mount TV adapter A is necessary

System Diagram

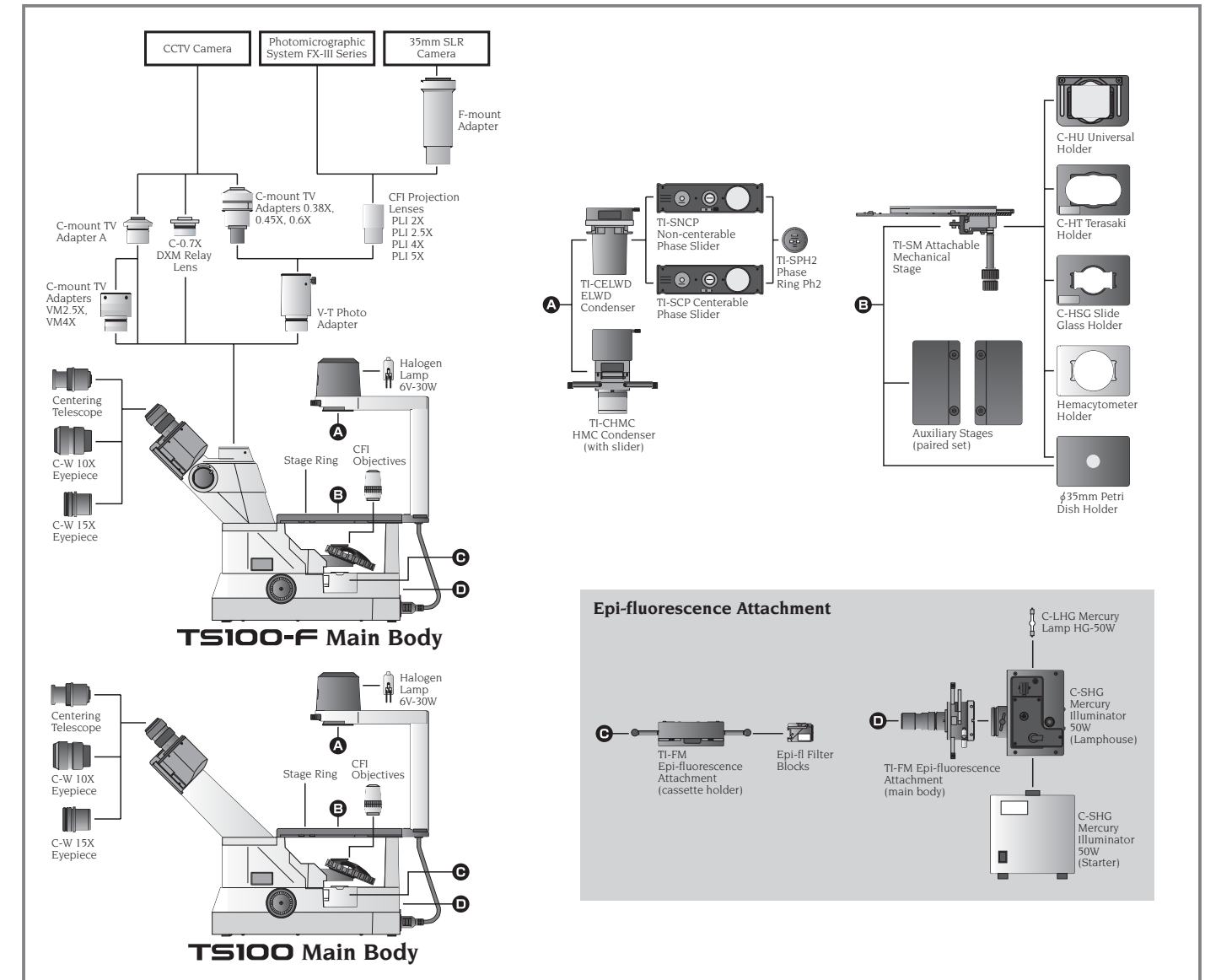

Dimensions

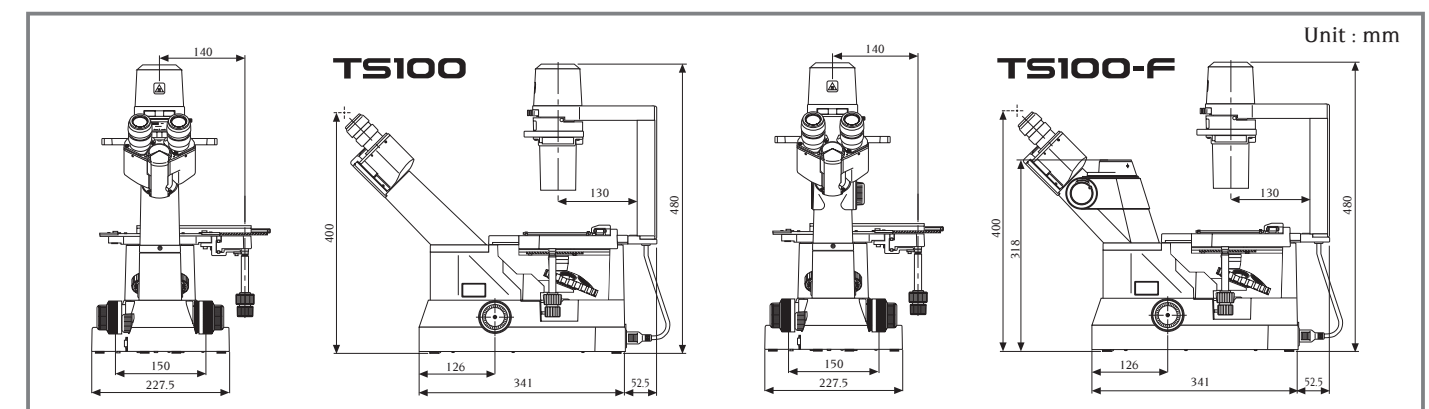

Specifications

	TS100 (Binocular model)	TS100-F (Trinocular model)
Optical system	CFI60 infinity system, parfocal distance 60mm	
Main body		
Main body	Square box type with both-end support stage	
Focusing	Vertical objective movement Coarse stroke: 37.7mm per rotation, Fine stroke: 0.2mm per rotation	
Eyepiece tube	Siedentopf-type binocular tube	Siedentopf-type trinocular tube (light distribution, bino/photo: 100/0, 0/100)
	Interpupillary distance: 50–75 mm, Eyepoint height: 400mm from table, Inclination: 45° from horizon	
Nosepiece	Quintuple nosepiece, backward-facing type	
Plain stage	Stage size: 170 x 225 mm, Stage height: 195mm from table, Auxiliary stage attachable	
Illumination	Pre-centered 6V-30W halogen lamp, Filter frame (accepts 2 filters), Heat absorbing filter and diffuser	
Slider	Non-centerable phase slider (PhL, Ph1, 1 empty position) Centerable phase slider (PhL, Ph1, 1 empty position), Ph2 ring (optional) HMC slider (MC1, MC2, MC3)	
Attachable mechanical stage	Stage movement: 126 x 80 mm Accepts several micro-testplate holders	
Holder	φ 35mm Petri Dish Holder Option: Universal Holder, Terasaki holder (accepts ø65mm petri dish), Slide glass holder (accepts ø54mm petri dish), Hemacytometer holder	
Filter	45mm NCB11, ND8 and GIF (green interference)	
Eyepiece lens	C-W 10X (F.O.V. 22mm), C-W 15X (F.O.V. 16mm)	
Condenser (without condenser O.D. 190mm)	ELWD condenser: N.A. 0.3 (O.D. 75mm) HMC condenser: N.A. 0.4 (O.D. 44mm)	
Epi-fluorescence attachment	Field diaphragm, Fluorescence filter block holder (2 filter blocks mountable, 1 empty position), Heat absorbing filter, Lamphouse for 50W mercury lamp, Light shielding plate, UV-cut filter (detachable)	

Note: Hoffman Modulation Contrast and HMC are registered trademarks of Modulation Optics, Inc.

Specifications and equipment are subject to change without any notice or obligation on the part of the manufacturer. January 2004.

©1999-04 NIKON CORPORATION

	WARNING	TO ENSURE CORRECT USAGE, READ THE CORRESPONDING MANUALS CAREFULLY BEFORE USING YOUR EQUIPMENT.
--	----------------	--



NIKON INSTECH CO., LTD.

Parale Mitsui Bldg., 8, Higashida-cho, Kawasaki-ku, Kawasaki, Kanagawa 210-0005, Japan
phone: +81-44-223-2167 fax: +81-44-223-2182
<http://www.nikon-instruments.jp/eng/>

NIKON INSTRUMENTS (SHANGHAI) CO., LTD.

CHINA phone: +86-21-5058-5055 fax: +86-21-5058-5060
NIKON SINGAPORE PTE LTD
SINGAPORE phone: +65-6559-3618 fax: +65-6559-3668
NIKON MALAYSIA SDN. BHD.
MALAYSIA phone: +60-3-78763887 fax: +60-3-78763887

NIKON INSTRUMENTS EUROPE B.V.

P.O. Box 222, 1170 AE Badhoevedorp, The Netherlands
phone: +31-20-44-96-222 fax: +31-20-44-96-298
<http://www.nikon-instruments.com/>

NIKON FRANCE S.A.

FRANCE phone: +33-1-45-16-45-16 fax: +33-1-45-16-00-33

NIKON GMBH

GERMANY phone: +49-211-9414-0 fax: +49-211-9414-322

NIKON INSTRUMENTS S.p.A.

ITALY phone: +39-55-3009601 fax: +39-55-300993

NIKON AG

SWITZERLAND phone: +41-43-277-2860 fax: +41-43-277-2861

NIKON UK LTD.

UNITED KINGDOM phone: +44-20-8541-4440 fax: +44-20-8541-4584

NIKON INSTRUMENTS INC.

1300 Walt Whitman Road, Melville, N.Y. 11747-3064, U.S.A.
phone: +1-631-547-8500; +1-800-52-NIKON (within the U.S.A. only) fax: +1-631-547-0306
<http://www.nikonusa.com/>

NIKON CANADA INC.

CANADA phone: +1-905-625-9910 fax: +1-905-625-0103



NIKON CORPORATION

Fuji Bldg., 2-3, Marunouchi 3-chome, Chiyoda-ku, Tokyo 100-8331, Japan
www.nikon.com/

